



CONTEMPORARY DRINKING FOUNTAINS

GR Series

MODEL GRM45
BARRIER FREE, BI-LEVEL
PEDESTAL MOUNTED
DRINKING FOUNTAIN

STANDARD FEATURES

- Resistant to sunlight, heat, moisture and wear
- 18 gage, 304 stainless steel Bowl
- 12 gage, heavy duty stainless steel, corrosion and scratch resistant finish
- Polished Stainless Steel, Anti-Rotation Non-Squirt Bubbler
- 100-Mesh Inlet Strainer
- Access Door, heavy duty stainless steel, vandal resistant
- Vandal resistant stainless steel Bottom Plate

SUGGESTED SPECIFICATIONS

Model GRM45 is a Barrier Free Pedestal Mounted, Vandal Resistant, Bi-Level Round Drinking Fountain made from 18 gage, 304 stainless steel Bowls mounted into a green powder coated 12 gage, heavy duty stainless steel Pedestal. Unit shall be activated by front mounted self-closing Buttons, by using less than 5 pounds of force, which activates internally mounted Valves with adjustable stream regulators controlling the water flow. Bubblers shall be polished stainless steel with non-squirt features and operate on water pressure range of 20 - 105 PSIG. Fountain is certified to ANSI A117.1, Public Law 111-380 (NO-LEAD), CHSC 116875 and NSF/ANSI 61, Section 9. Fixture meets ADA, ADA Standing Person, and ADA Child requirements when mounted appropriately.

Options Notes:

¹ See separate option sheet.

² This option is not available freeze-resistant.



Model GRM45-PF Shown

MODEL:

(Must Specify)

- GRM44 Satin stainless finish
- GRM45 Green powder-coated (Shown)
- GRM46 Red powder-coated
- GRM47 Blue powder-coated

Custom color finishes available upon request

OPTIONS

(additional costs may be incurred)

- CH30 Child height, 30" Bubbler height
- FRU2 Freeze resistant, 2 Valves ¹
- FRU3 Freeze resistant, 3 Valves ¹
- FRU4 Freeze resistant, 4 Valves ¹
- FS Foot Shower
- HB1 Hose Bibb, compression, with hose threaded outlet/VB ^{1 2}
- HB3 Hose Bibb, loose key, vandal resistant, locked door with hose threaded outlet/VB ^{1 2}
- IAP In-ground Anchor Plate
- IGM In-ground 14" Mounting Adapter
- JF1 Jug Filler, Spigot, self-closing Valve with Plain End ^{1 2}
- JF2 Jug Filler, Pushbutton, self-closing Valve w/ Plain end ¹
- JFFR1 Jug Filler, Pushbutton, Freeze Resistant, self-closing Valve ¹
- NP2 Non-Pollutable, Freeze Resistant, 2 Valves
- NP3 Non-Pollutable, Freeze Resistant, 3 Valves
- PF Pet Fountain Receptor ¹

Complies with the following standards:



Member of U.S. Green Building Council



Recyclable Product



Water Conserving Product

⚠ WARNING: Cancer and Reproductive Harm - www.P65Warnings.ca.gov

MURDOCK MFG. • 15125 Proctor Avenue • City of Industry, CA 91746 USA
Phone 800-453-7465 or 626-333-2543 • Fax 626-855-4860 • www.murdockmfg.com

Member of MORRIS GROUP INTERNATIONAL



CONTEMPORARY DRINKING FOUNTAINS

GR Series

MODEL GRM45 BARRIER FREE, BI-LEVEL PEDESTAL MOUNTED DRINKING FOUNTAIN

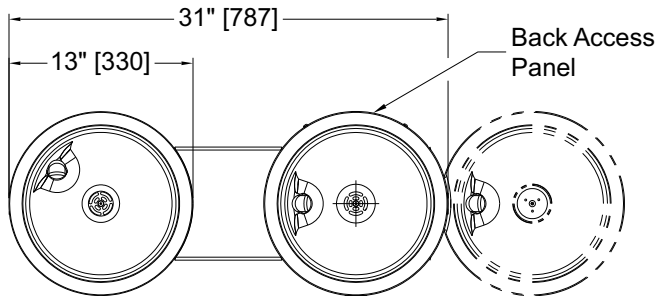

* Valve specifications:
Minimum/Maximum Pressure
30 to 100 PSI.

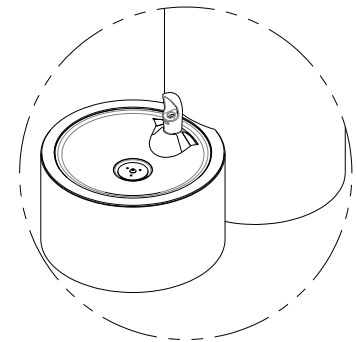

**OPTIONAL -PF PET FOUNTAIN
DETAIL**

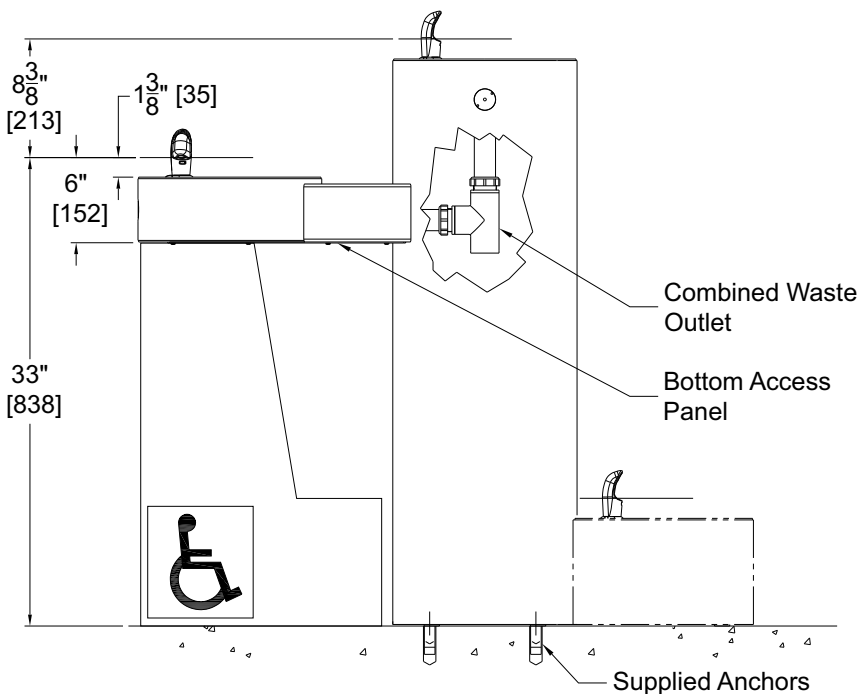

General Notes:

1. All dimensions are in inches [mm].
- *2. Standard adult ADA height model shown. Optional -CH30 child ADA height model available.
3. Stop Valve not provided.

Murdock Mfg.™ warrants that its products are free from defects in material or workmanship under normal use and service for a period of one year from date of shipment. Murdock's liability under this warranty shall be discharged solely by replacement or repair of defective material, provided Murdock™ is notified in writing within one year from date of shipment, F.O.B. Industry, California.

SELECTION SUMMARY & APPROVAL FOR MANUFACTURING	Model Number & Options _____	Quantity _____	All dimensions are subject to manufactures tolerance of plus or minus 1/2" nominal and subject to change without notice. Murdock assumes no responsibility for use of void or superseded data. Dimensions may change with the addition of optional accessories. Murdock Mfg.™, Member of Morris Group International™. Please visit www.murdockmfg.com for most current specifications.
	Company _____		
	Contact _____	Title _____	
	Signature (Approval for Manufacturing) _____	Date _____	